

ENERGY RECOVERY VENTILATOR (ERV)

MODEL VEB120S

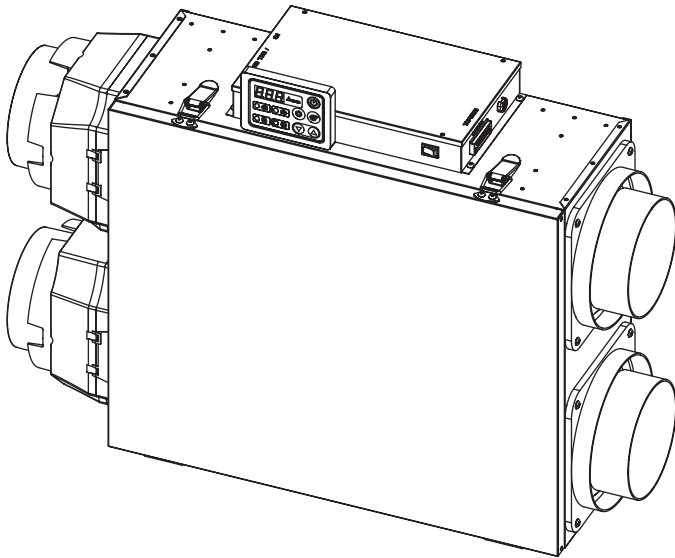

TABLE OF CONTENTS

GENERAL SAFETY INFORMATION	2
SPECIFICATIONS	5
UNPACKING AND LISTING	6
OVERVIEW	8
INSTALLATION	9
WIRING DIAGRAM	17
OPERATION	19
INSTALLATION (CONTROL PANEL)	20
CONTROL PANEL	21
MAINTENANCE	25
TROUBLE SHOOTING	27
WARRANTY	28

READ AND SAVE THESE INSTRUCTIONS

Address: 46101 Fremont Boulevard, Fremont, CA 94538

US Toll Free Number:

1-888-979-9889 – Technical Support

1-877-685-4384 – Customer Sales Support

www.deltabreez.com

Remove plastic bag of filter before installation

GENERAL SAFETY INFORMATION

Recognize and read these safety information carefully before installing and operating the ERV product. This is the safety--alert symbol when you see this symbol on the unit and in instructions or manuals, be alert to the potential for personal injury.

 WARNING	A WARNING alert with the safety alert symbol indicates a potentially hazardous situation that could result in serious injury or death.
CAUTION	A CAUTION alert with the safety alert symbol indicates a potentially hazardous situation that could result in minor or moderate injury.

NOTE: This symbol indicates an installer or a user note. Notes provide additional information to supplement the instructions, or tips for easier operation.

WARNING

TO REDUCE THE RISK OF FIRE, ELECTRIC SHOCK, OR INJURY TO PERSONS, OBSERVE THE FOLLOWING:



1. Use this unit only in the manner intended by the manufacturer. If you have questions, contact the manufacturer.
2. Before servicing or cleaning this unit, disconnect power cord from electrical outlet.
3. Installation work and electrical wiring must be done by qualified person(s) in accordance with all applicable codes and standards, including fire-rated construction.
4. Sufficient air is needed for proper combustion and exhausting of gases through the flue (chimney) of fuel burning equipment to prevent back drafting. Follow the heating equipment manufacturer's guideline and safety standards such as those published by the National Fire Protection Association (NFPA), and the American Society for Heating Refrigeration and Air Conditioning Engineers (ASHRAE) and local code authorities.
5. When cutting or drilling into wall or ceiling, do not damage electrical wiring and other hidden utilities.
6. Do not use this unit with any solid-state speed control device.
7. This unit must be grounded. The power supply cord has a 3-prong grounding plug for your personal safety. It must be plugged into a mating 3-prong grounding receptacle, grounded in accordance with the national electrical code and local codes and ordinances. Do not remove the ground prong. Do not use an extension cord.
8. Do not install in a cooking area or connect directly to any appliances.
9. Do not use to exhaust hazardous or explosive materials and vapors.
10. When performing installation, servicing or cleaning this unit, it is recommended to wear safety glasses and gloves.
11. When applicable local regulation comprises more restrictive installation and/or certification requirements, the aforementioned requirements prevail on those of this document and the installer agrees to conform to these at his own expense.

CAUTION

1. To avoid prematurely clogged filters, turn the unit OFF during construction or renovation.
2. Please read specification label on product for further information and requirements.
3. Be sure to duct air outside – Do not intake/exhaust air into spaces within walls or ceiling or into attics, crawl spaces, or garage. Do not attempt to recover the exhaust air from a dryer or a range hood.
4. Do not run any air ducts directly above or within 2 ft (0.61 m) of a furnace or its supply plenum, boiler, or other heat producing appliance. If a duct has to be connected to the furnace return plenum, it must be connected 10 ft (3.1 m) away from plenum's connection to the furnace.
5. The ductwork is intended to be installed in compliance with all applicable local and national codes.

GENERAL SAFETY INFORMATION

6. When leaving the house for a long period of time (more than two weeks), a responsible person should regularly check if the unit operates adequately.
7. If the ductwork passes through an unconditioned space (e.g.: attic), the unit must operate continuously except when performing maintenance and/or repair. Also, the ambient temperature of the house should never drop below 18°C (65°F).
8. At least once a year, the unit mechanical and electronic parts should be inspected by qualified service personnel.
9. Do not use your unit during construction or renovation of your house or when sanding drywall. Certain types of dust and vapors may damage your system.
10. Make sure at all times that the outside intake and exhaust hoods are free from any snow during the winter season. It is important to check your unit during a big snow storm, so it doesn't draw in any snow. If this is the case, please turn the unit OFF for a few hours.
11. Since the electronic control system of the unit uses a microprocessor, it may not operate correctly because of external noise or very short power failure. If this happens, unplug the unit and wait approximately 10 seconds. Then, plug the unit in again.
12. Do not make excessive use of fragrance appliances or chemicals since some may damage the unit components material.

 WARNING	The wearing of safety glasses and gloves is recommended when installing, maintaining or cleaning the unit to reduce the risk of injury that could be caused by the presence of thin metal and/or high moving parts.
CAUTION	Make sure that no piece of mineral wool will enter in the unit during installation. Otherwise, this could reduce airflow and generate vibrations and noise in the unit.
 PROHIBITED	An IMPORTANT alert with the damage alert symbol indicates a situation that may result in damage to the equipment.

IMPORTANT

TO REDUCE THE RISK OF FIRE, ELECTRIC SHOCK, OR INJURY TO PERSONS, OBSERVE THE FOLLOWING:

1. Make sure that the electric service supply voltage is AC 120V, 60Hz.
2. Follow all local electrical and safety codes, as well as the National Electrical Code (NEC) and the Occupational Safety and Health Act (OSH Act).
3. Always disconnect the power source before working on or near the ventilating fan, motor or junction box.
4. Protect the power cord from sharp edges, oil, grease, hot surfaces, chemicals or other objects.
5. This unit is UL listed for use over a bathtub or shower when installed in a GFCI-protected branch circuit.
6. Provide intake parts with proper ventilation.
7. Do not kink the power cord.
8. Do not install the unit where ducts are configured as shown below.

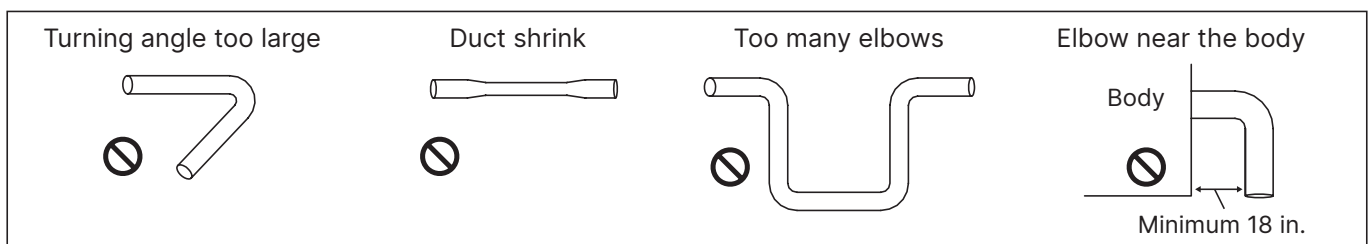

GENERAL SAFETY INFORMATION

CAUTION

Do not install the equipment in the following places:

- **High Temperature or the Heated Place**

ERV equipment should not be installed in places with temperatures exceeding 104°F(40°C). High temperature will cause distortion or damage to the filters, heat exchanger core or motors.

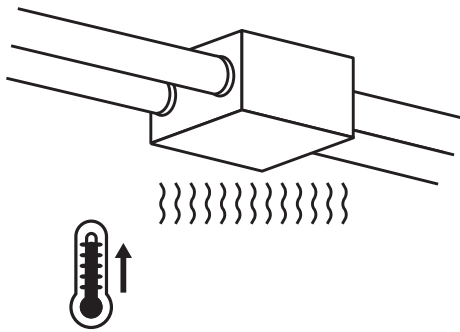

- **Wet Place**

Do not install in the place where humidity is over 85% such as in the bathroom, or it will cause electric shock or electric device malfunction.

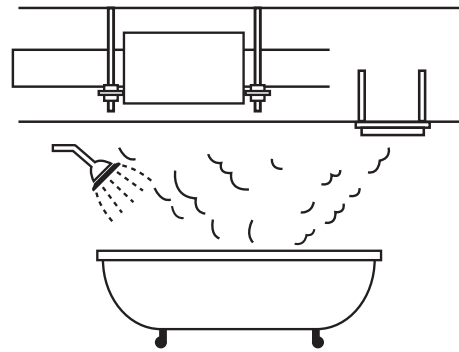

- **Heavy Oil Smoke Place**

The filters and the heat exchanger core can't be used if attached by heavy oil smoke.

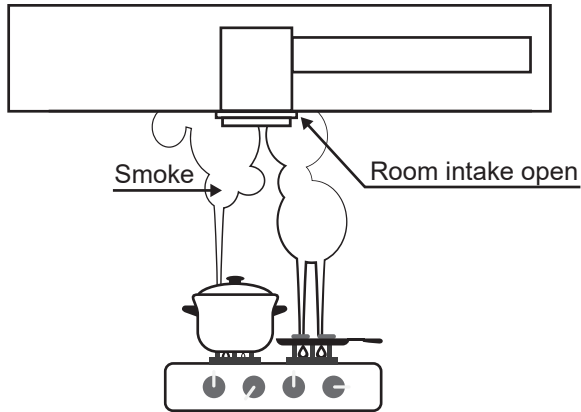

- Make sure that the installation of the checkup opening is convenient for the maintenance of the filter and the ERV core and the checkup of the machine.

- Please do not install the machine in the places such as machinery factory or chemical factory where acid, alkali, organic solvent, dope or other harmful air and erodible air such as dust and oil smoke may be produced.

- Remove plastic bag of filter before installation.

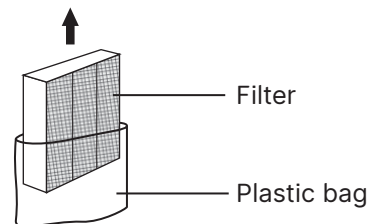

SPECIFICATIONS

Dimensions	Unit - 22½"(572 mm) L × 19"(485 mm) W × 8⅝"(219 mm) H Energy Recovery CORE - 10¼" (260 mm) × 10¼" (260 mm) × 7" (180 mm)
Weight	36 lbs (16 kg)
Power	120 Vac, 1.26 Amp Maximum. Unit Equipped with 5 ft (1.5 meter) Ground Power Cord
Filter	A MERV 13 and Plastic Mesh Type at Outside Air Side, A Plastic Mesh Type at Stale Air Side
Airflow	118 CFM (56 L/s) at 0.4" w.g. (100 Pa) External Differential Static Pressure
Fan speed	Multi- Speed at 30 CFM to 120 CFM

VENTILATION PERFORMANCE

Inch w.g. (Pa)	Net supply airflow CFM (L/s)
0.2 (50)	131 (62)
0.4 (100)	118 (56)
0.6 (150)	101 (48)
0.8 (200)	83 (39)
1.0 (250)	64 (30)

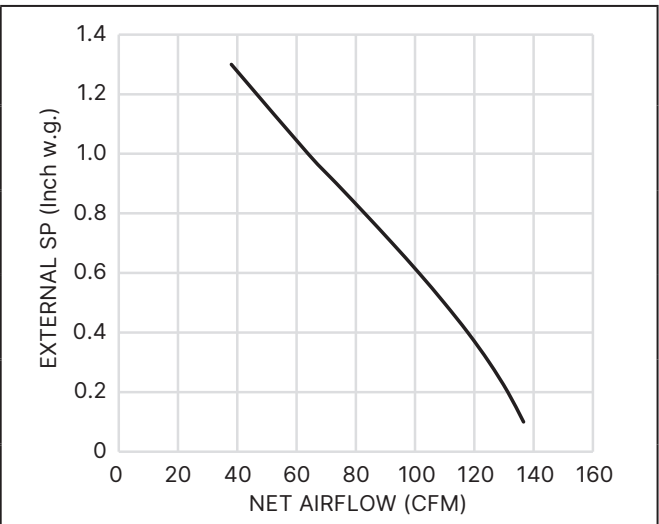

The graph plots External SP (Inch w.g.) on the y-axis (0 to 1.4) against NET AIRFLOW (CFM) on the x-axis (0 to 160). The curve starts at approximately (131, 0.2) and ends at (64, 1.0), showing that as net airflow decreases, the external static pressure increases.

ENERGY PERFORMANCE

Heating mode	Sensible Recovery Efficiency (SRE)	32°F (0°C)	35 CFM (17 L/s)	77%
Heating mode	Sensible Recovery Efficiency (SRE)	32°F (0°C)	64 CFM (30 L/s)	75%
Heating mode	Sensible Recovery Efficiency (SRE)	32°F (0°C)	107 CFM (50 L/s)	70%
Heating mode	Sensible Recovery Efficiency (SRE)	-13°F (-25°C)	35 CFM (17 L/s)	57%
Cooling mode	Total Recovery Efficiency (TRE)	95°F (35°C)	35 CFM (17 L/s)	75%
Cooling mode	Total Recovery Efficiency (TRE)	95°F (35°C)	64 CFM (30 L/s)	62%

- Engineering design and specifications to change without notice

Requirements and standards

Complies with the UL 1812 and C 22.2 No. 113-18 requirements regulating the construction and installation of Heat Recovery Ventilators Technical data was obtained from published results of test relating to CSA C439 Standards.

UNPACKING AND LISTING





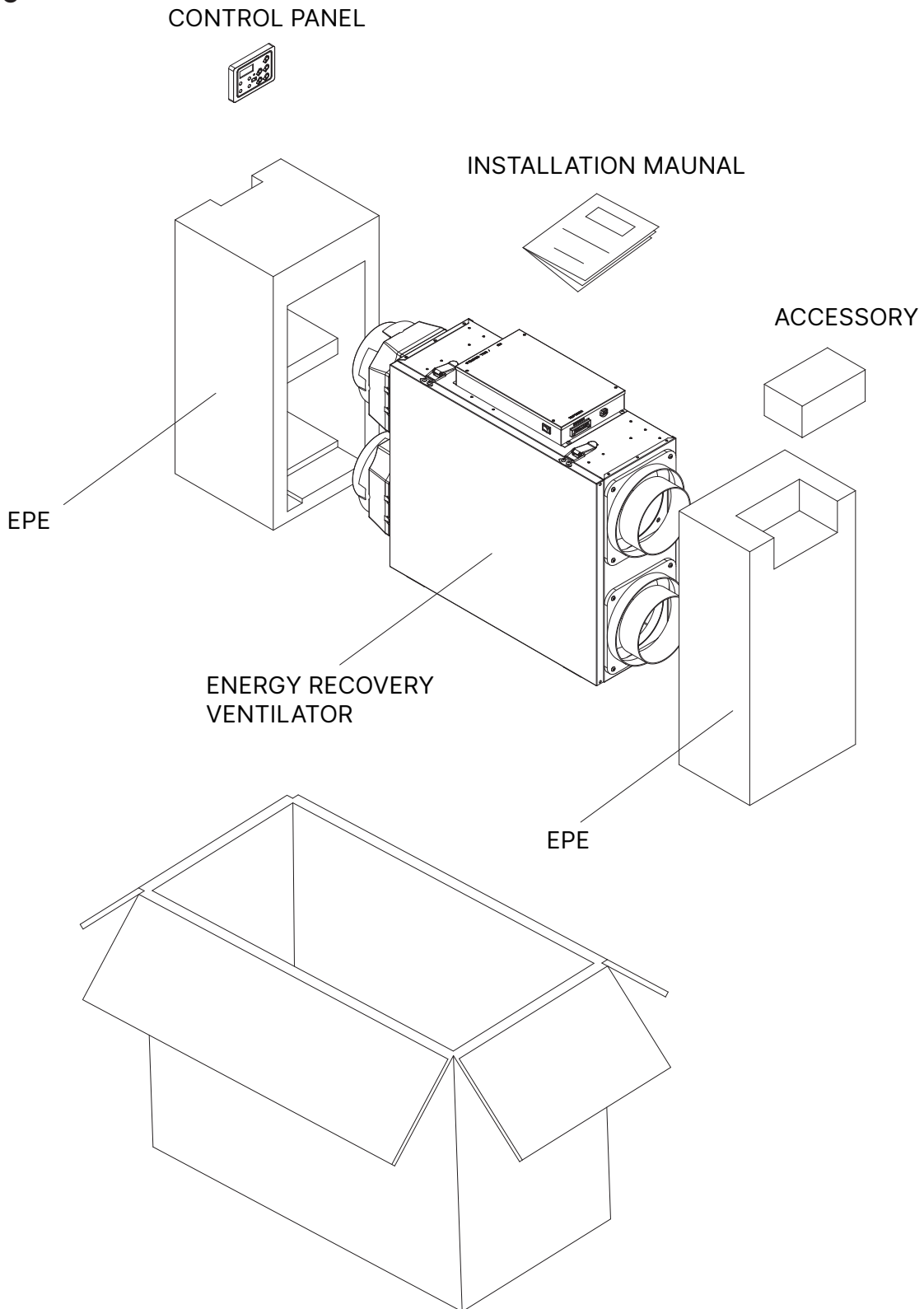

Please unpack and remove the carton carefully then follow the diagram as below to verify all unit are presented.

OPENING

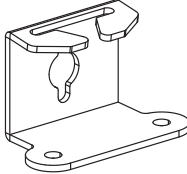

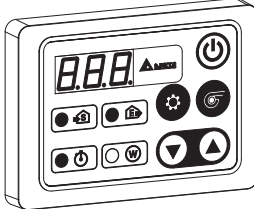
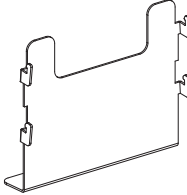
UNPACKING AND LISTING

PART LIST

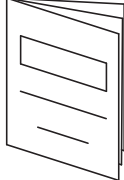
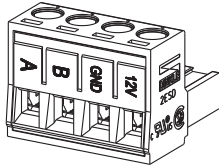
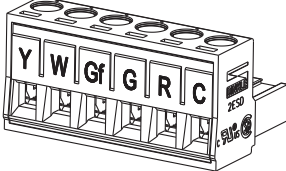
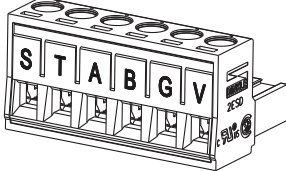
Part name	Appearance	Quantity
MOUNTING BRACKET		4
CHAIN		4
CONTROL PANEL		1
PANEL BRACKET		1
MACHINE SCREW (M4 × 6 mm)		10
TAPPING SCREW (T4 × 25 mm)		4
CABLE TIES		4
INSTALLATION MAUNAL		1
4P TERMINAL		1
6P TERMINAL	<div style="display: flex; justify-content: space-around;"> <div style="text-align: center;"> <p>Interlock</p>  </div> <div style="text-align: center;"> <p>Wall switch</p>  </div> </div>	1 of each

OVERVIEW

Energy recovery ventilator shall be Delta Breez model VEB120S, ECM-motor engineer runs continuously for a minimum 60,000 hours; airflow rating of from 30 to 118 CFM at 0.4" w.g. static pressure. With efficiency rating of not less than 1.22 CFM/Watt at 0.4" w.g. static pressure. Housing shall be insulated to reduce condensation and noise. MERV 13 filter is a superior filter and is required in many cases by code or IAQ program recommendations. Backdraft damper shall be motorized. Interlock control can be hardwired to the HVAC system. The filter alert has two step alert for cleaning and replacement.

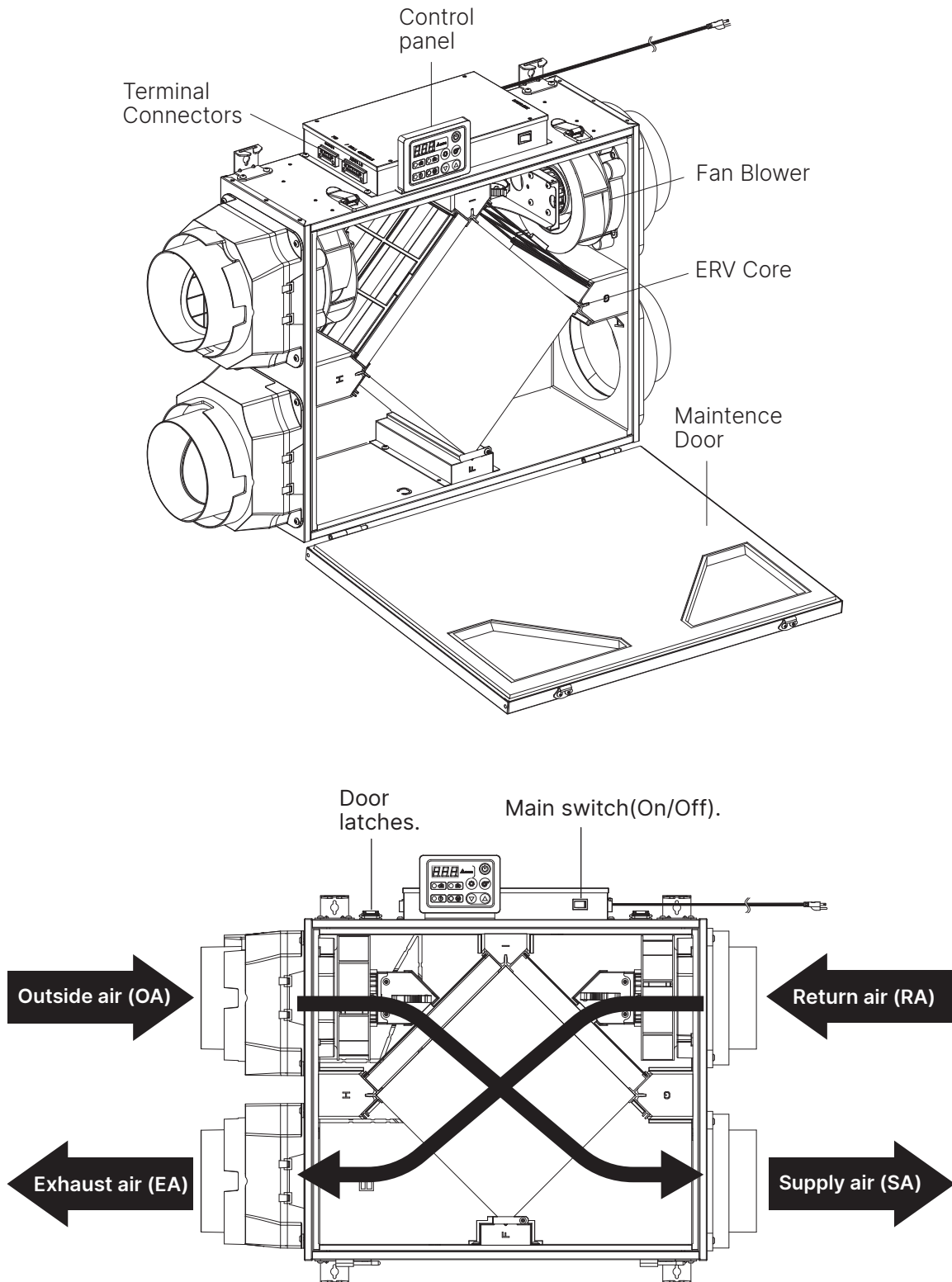

INSTALLATION (Wall mounted)

- Using the hardware provided, install the mounting brackets on the unit. It is important to isolate the mounting brackets from the mounting surface to minimize vibration.
- Use the provided MACHINE SCREW (M4 × 6 mm) to install the mounting brackets onto the surface of the equipment.

4 pcs mounting brackets

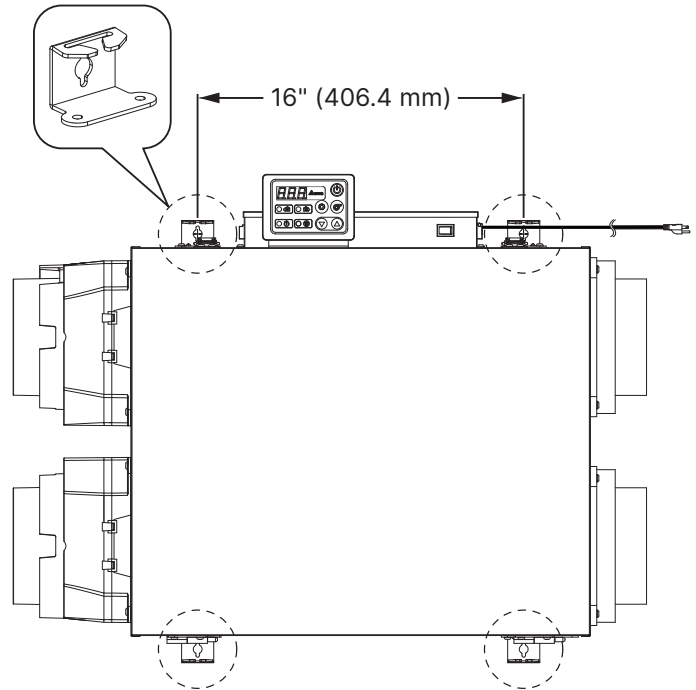

- Choose the appropriate location(s) for the mounting brackets (see illustration right) according to stud(s) position.
- Insert the provided brackets under the unit frame (see illustration hereafter).
- Secure the bracket via the screw T4 × 25 mm.

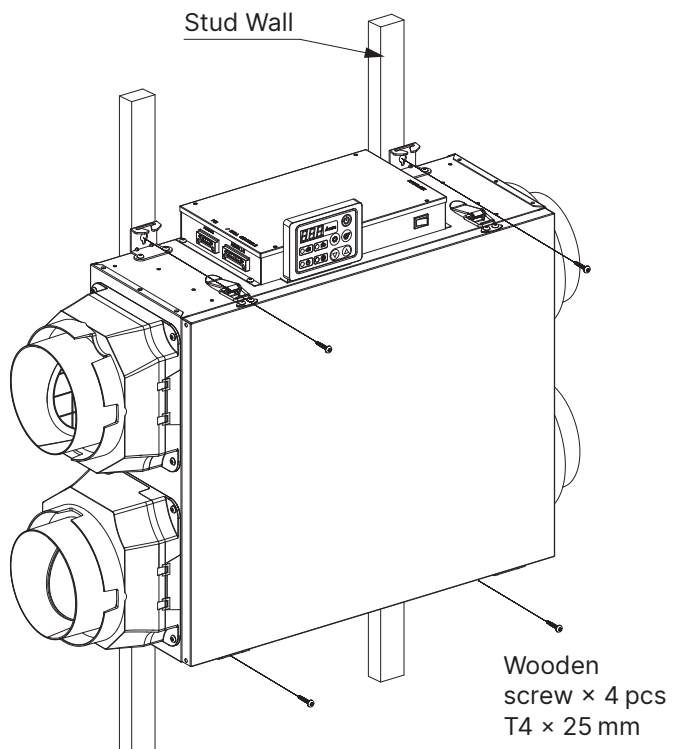
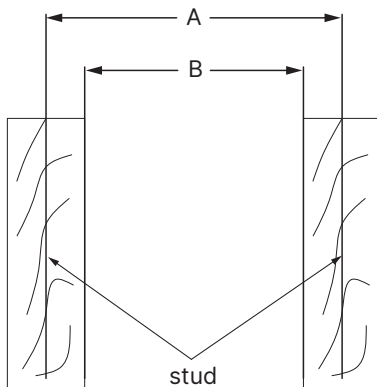

Unit : inches (mm)

A	B
16 (406.4)	14½ (368.3)
19 (482.6)	17½ (444.5)

INSTALLATION (Wall mounted)

- Using the T4 × 25 mm screws provided, secure the unit to the wall making sure that the 3 screws engage into a stud.

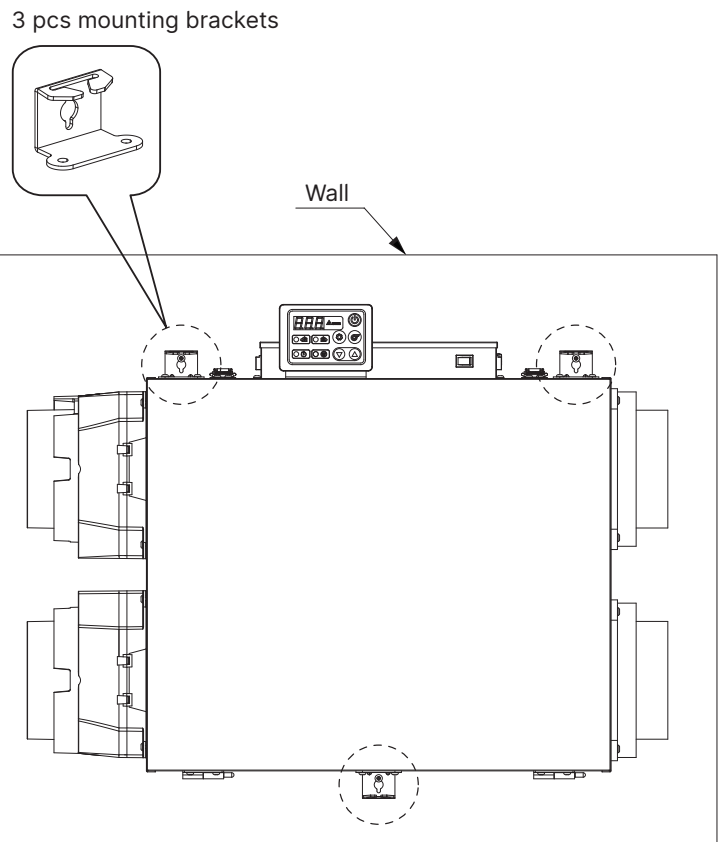

- Always make sure that the unit is no more than ¼" off level.

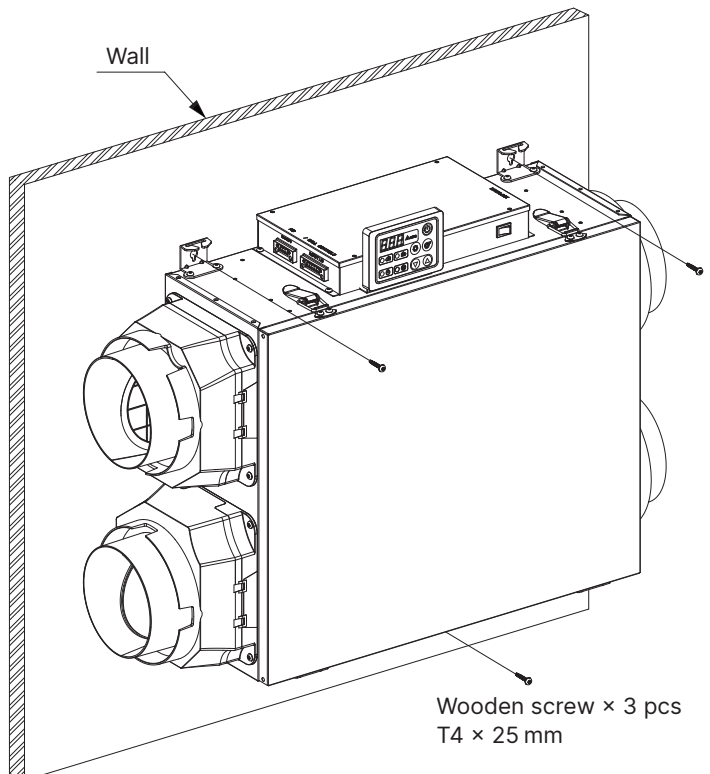

INSTALLATION (Under ceiling mounted)

Using 8 screws (M4×6 mm), install the brackets on the unit, and using 4 screws (T4×25 mm) secure the unit to the ceiling, into the studs, joists or other solid materials.

4 pcs mounting brackets

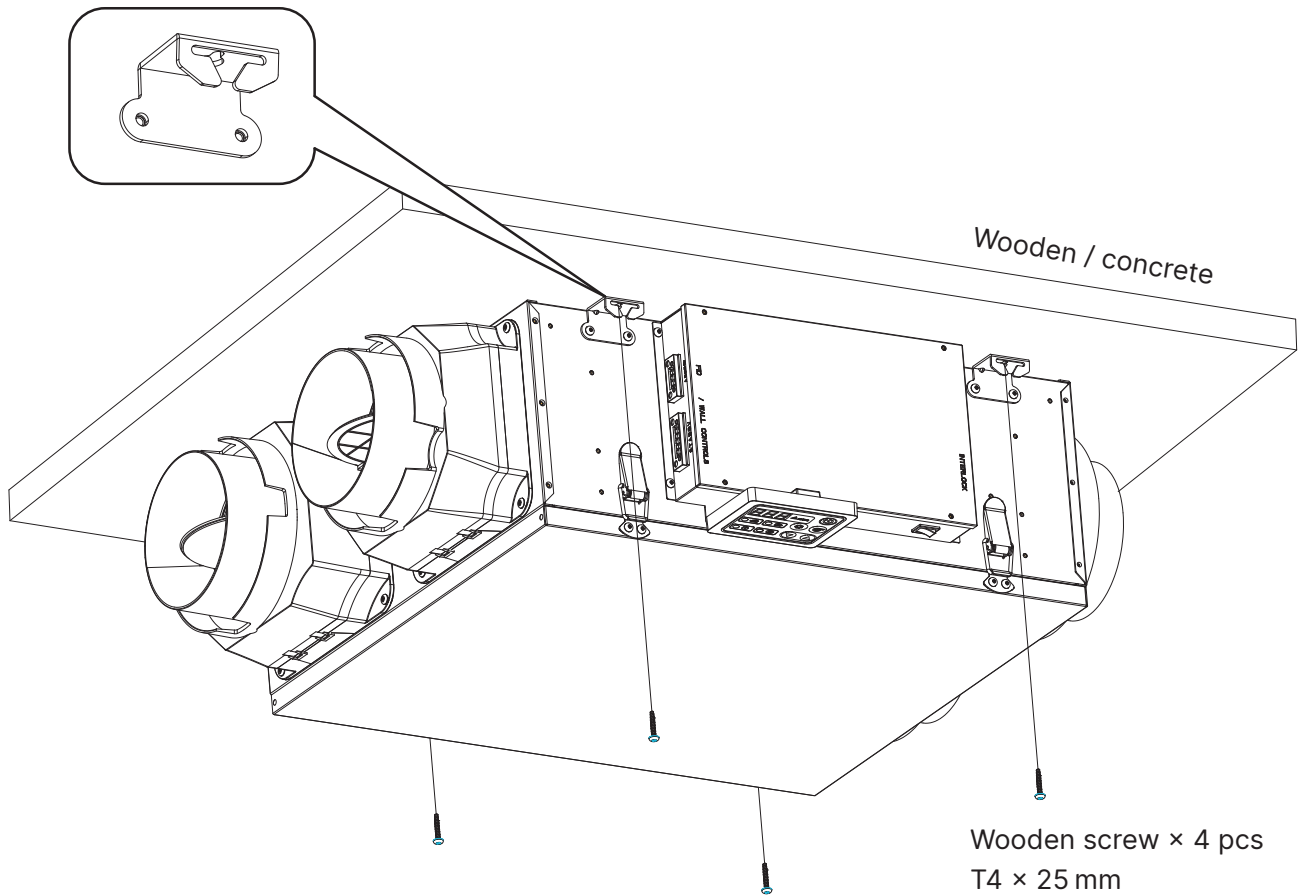

INSTALLATION (Chain mounted)

1. Adopt mounting brackets with the unit to insert the provided chains.
2. Hang the unit to the joists using the provided chains.
3. Always make sure that the unit is no more than $\frac{1}{4}$ " off level.

Unit: inches (mm)

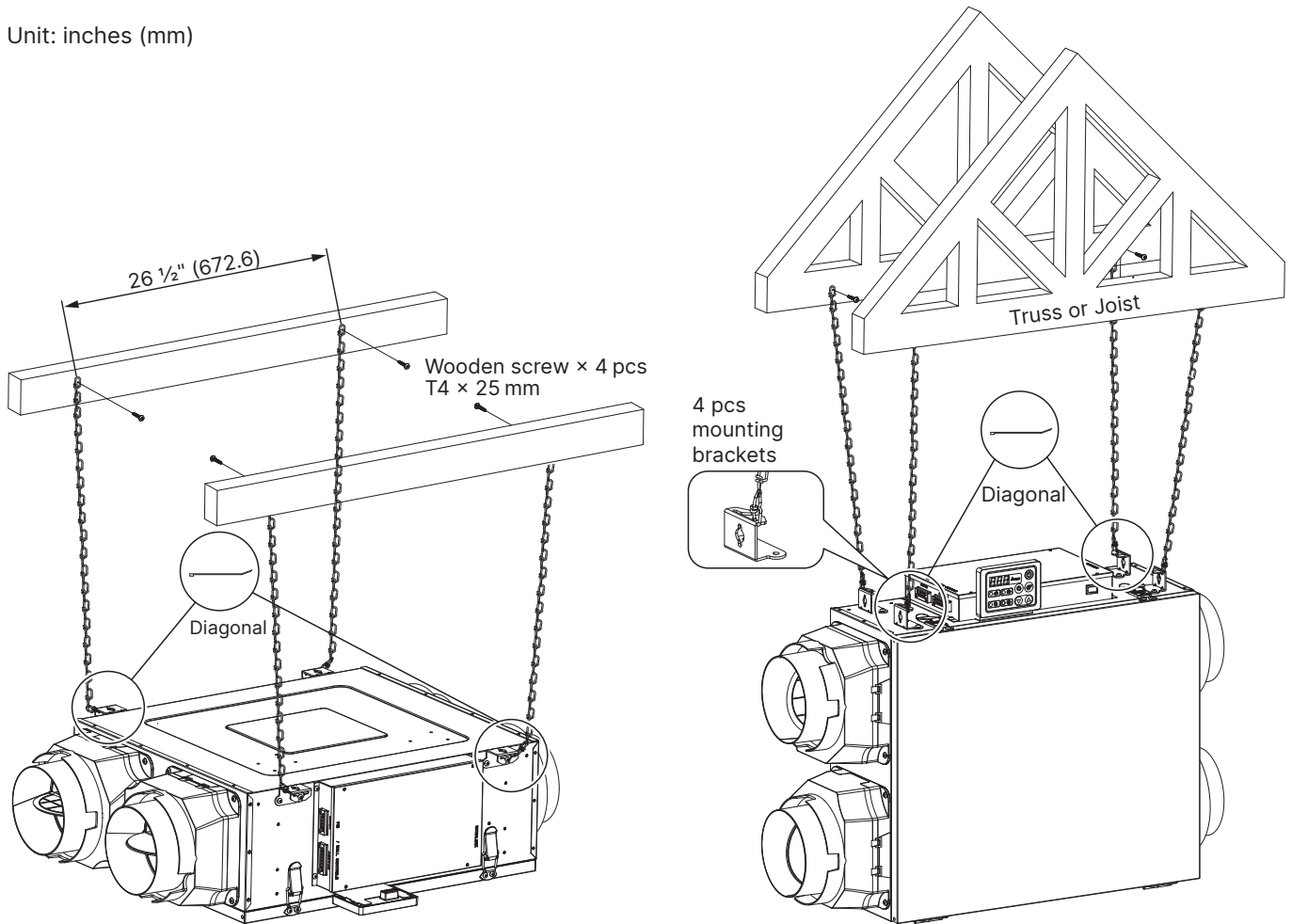

INSTALLATION (Ductwork)

 WARNING	<p>Never install a stale air exhaust register in a room where there is a combustion device, such as a furnace, gas water heater, fireplace or any appliance or equipment that can generate gaseous contaminants, or pollutants. The negative pressure this could create in the room may impair proper evacuation of the gas or pollutants, which may have severe health consequences.</p>
CAUTION	<p>If ducts have to go through an unconditioned space (e.g.: attic), always use insulated ducts to prevent condensation formation inside and outside ducts, which could cause material damage and/or mold growth. Moreover, if fresh air to building duct and/or stale air from building duct goes/go through an unconditioned space, the unit must be set to operate continuously in cold conditions (below 10°C/50°F). Continuous air movement inside ducts will prevent condensation formation. The unit can be stopped temporarily for maintenance and/or repair purposes in such conditions.</p>

FULLY DUCTED SYSTEMS

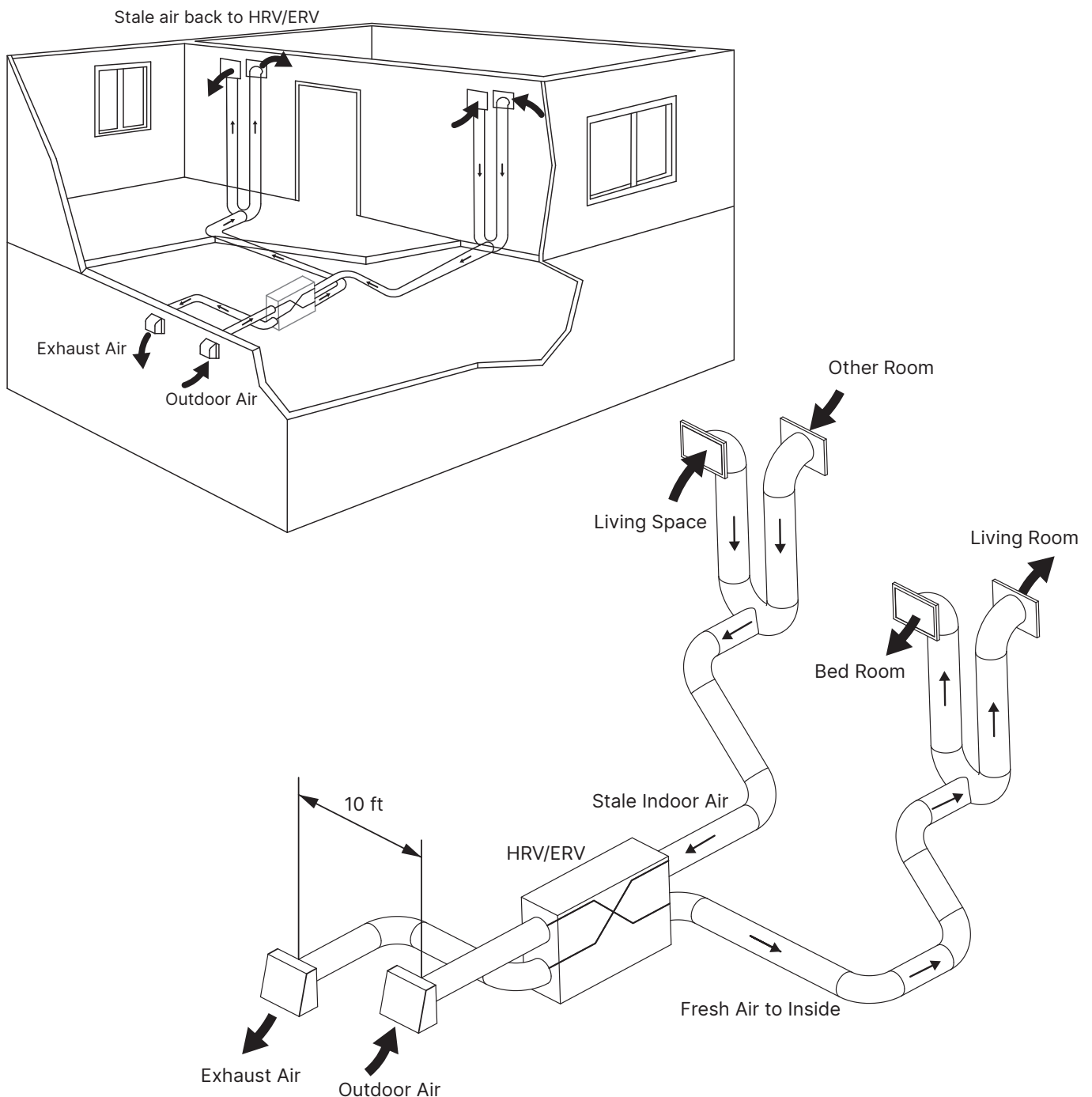

INSTALLATION (Ductwork)

The installation method must be interlocked between HRV/ERV and Furnace/Air Handler, otherwise this is prohibited.

A+B=10 ft or greater from furnace/air handler fan to HRV/ERV fresh air to inside duct

C=Space a minimum of 3 ft apart

D=Space a minimum of 3 ft apart

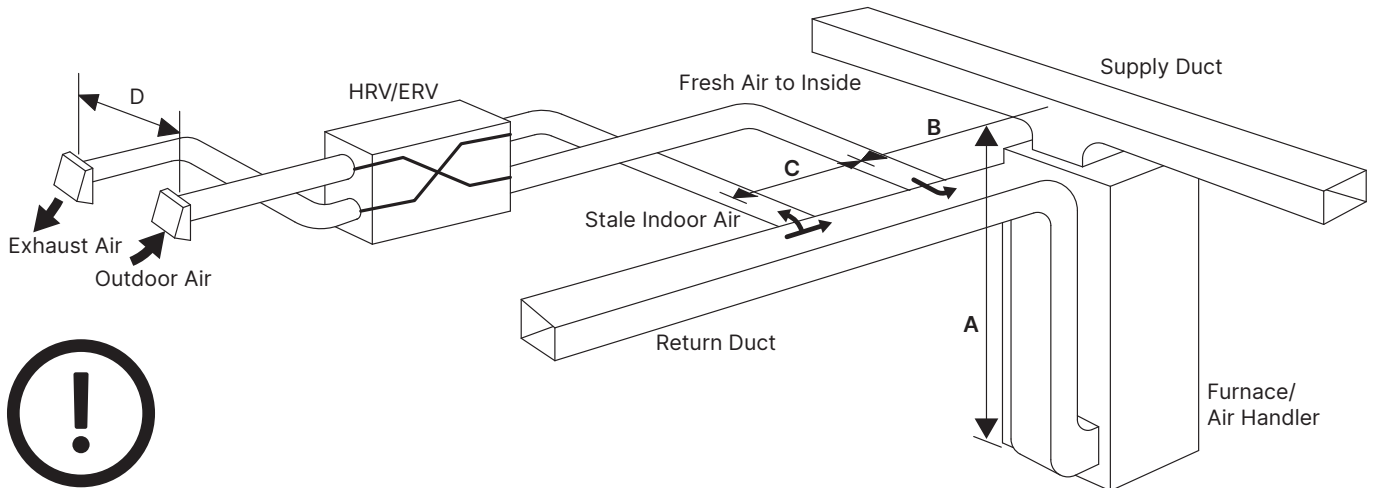

CAUTION

Use the following procedure to connect the insulated flexible ducts to the ports of the unit (exhaust to outside and fresh air from outside).

1. Expose the flexible duct by pulling back the insulation, and place it over the inner port ring.
2. Attach the flexible duct to the port using a tie wrap.
3. Seal the joint using duct tape.
4. Pull the insulation and vapor barrier over the joint, tuck them between the inner and outer rings of the double collar and fasten them in place using duct tape.

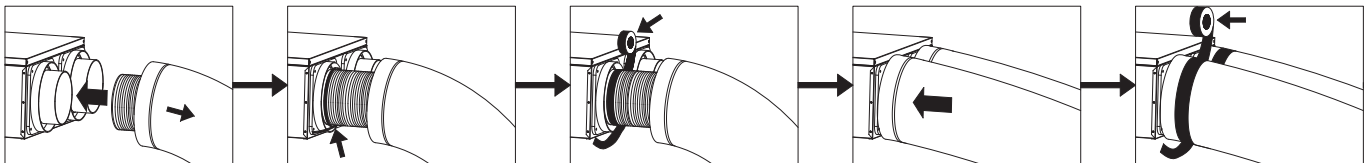

Connecting insulated flexible air ducts to the ports

Method (1): Fully Dedicated Air Duct

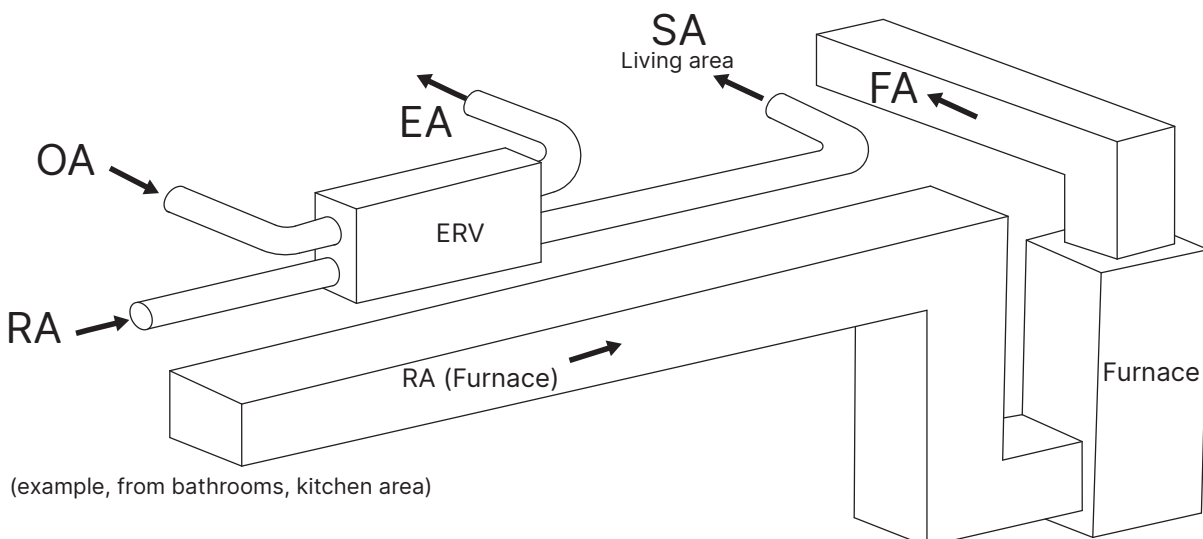

INSTALLATION (Ductwork)

Method (2):
Separate Room Exhaust Air Pick-Up / Fresh Exchanged Outside Air to Central System Return Air

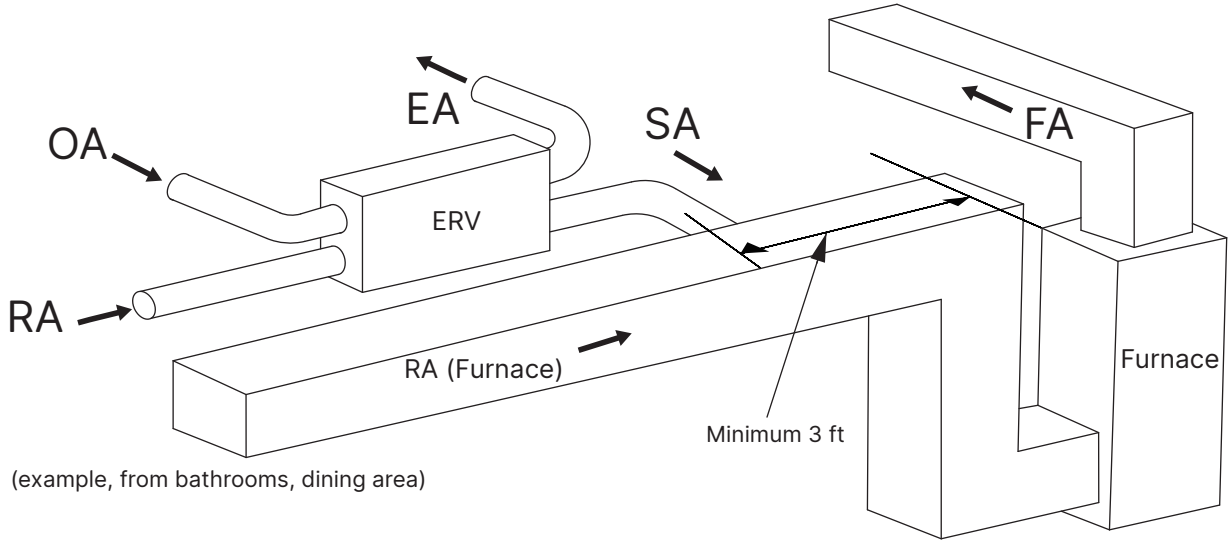

Method (3):
Exhaust Air from Return Duct/ Fresh Air Ducted to Supply Air Duct

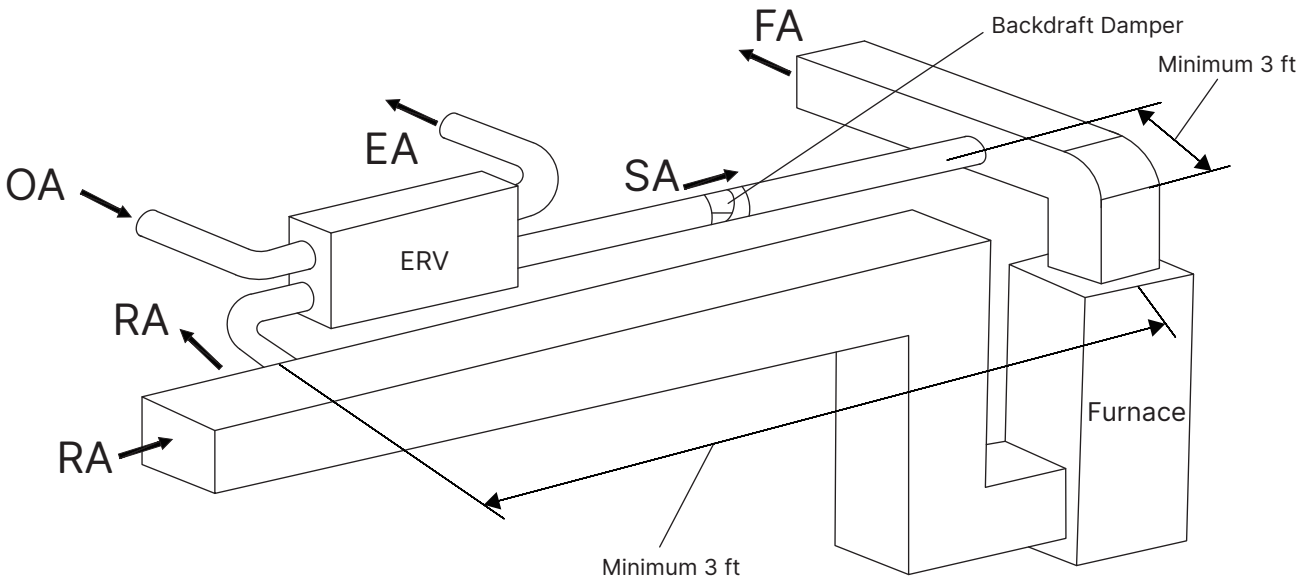

INSTALLATION (Ductwork)

CAUTION

The exhaust outlet and fresh air inlet on the outside of the building should be at least 10 feet apart to avoid cross contamination. The Outdoor fresh air inlet must be located a minimum of 10 feet from any other exhaust vent, gas meter, outdoor grill, or source of open flame. Fresh air inlets must also be located a minimum of 10 feet from oil tank fill tubes, garbage cans and any other source of contamination. Fresh air inlet and outlets should not be installed in areas of stagnant air. Fresh air inlet and outlet hoods should be located a minimum of twelve 1 feet above the normal snow level.

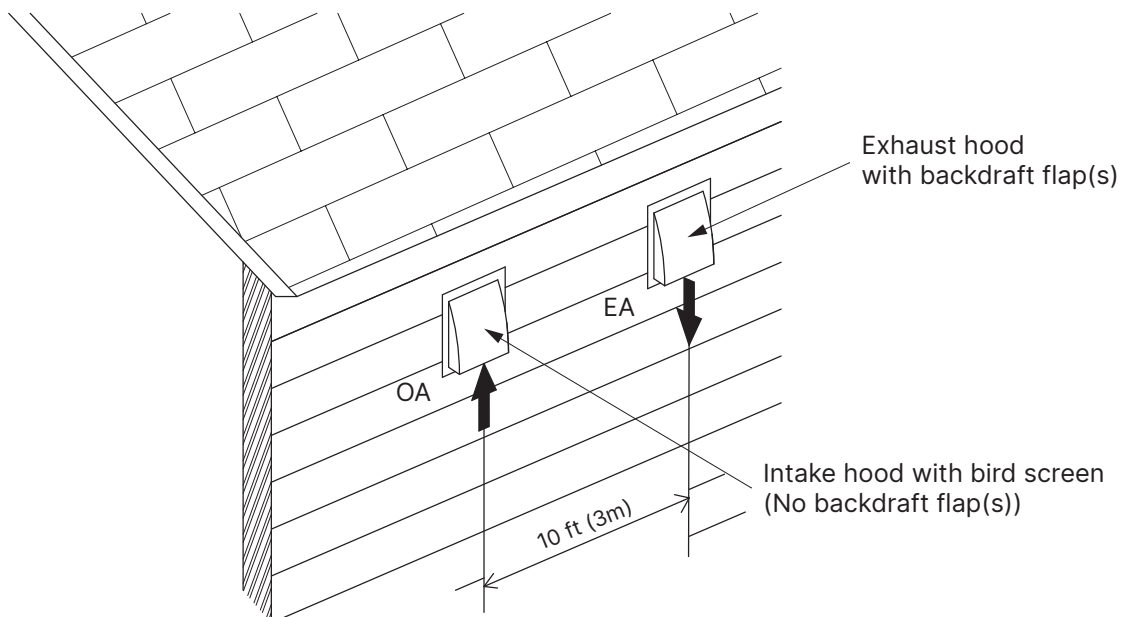
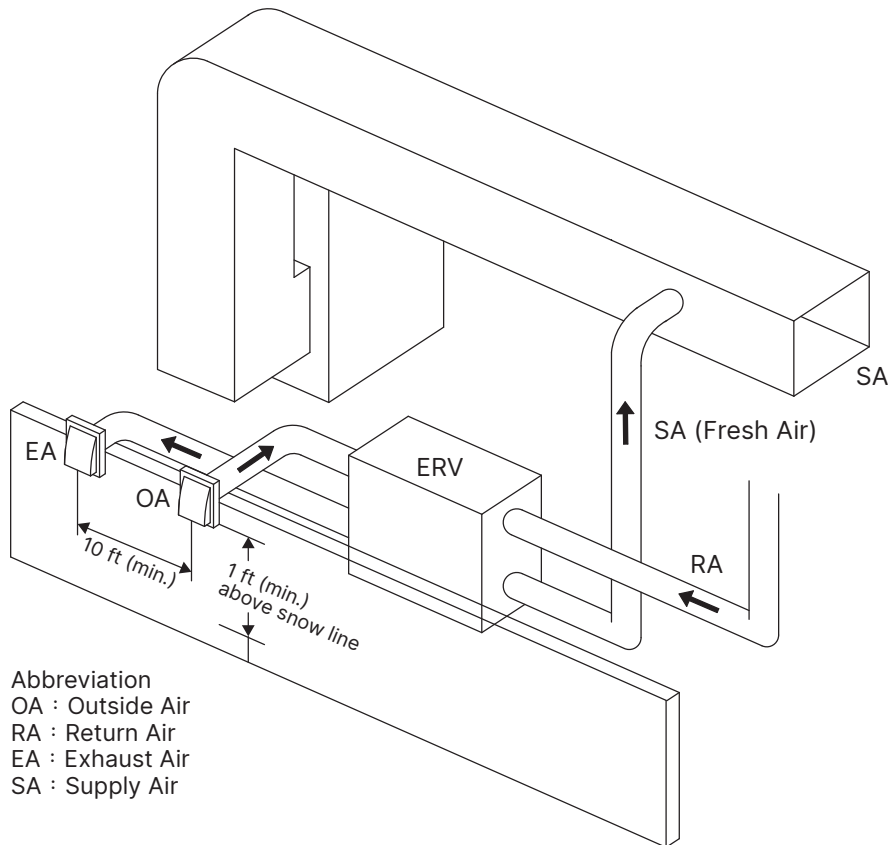

WIRING DIAGRAM

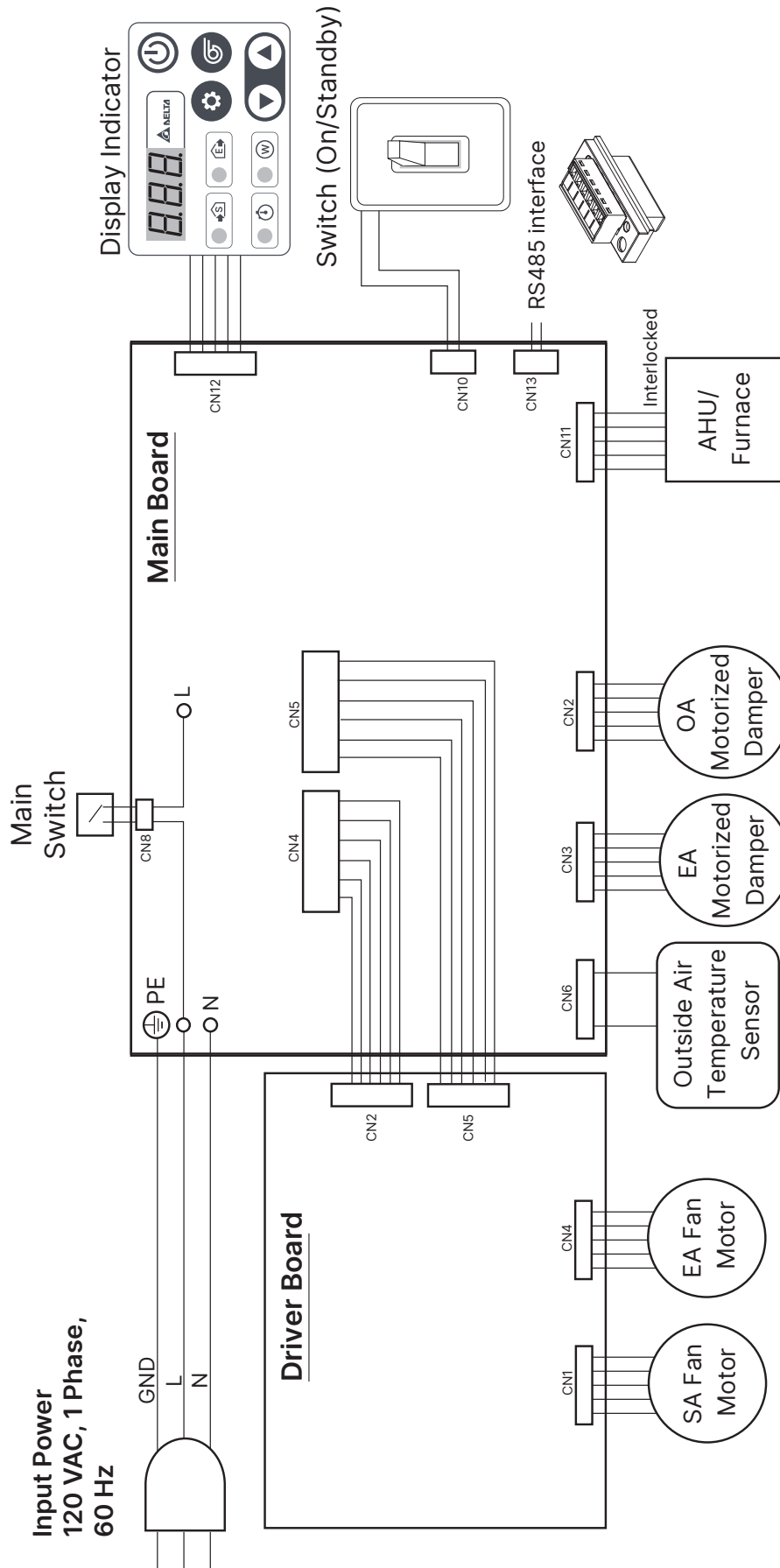

WIRING DIAGRAM

Suitable for VEB120S model

Unit wiring: Use 4 wire AWG #20 (min.), 100 ft length (max.).

Interlock

Note: Run time function is disable when Y/W/G is enable.

Synchronized: Start AHU/Furnace blower when VEB120S is running

Not Synchronized: Start AHU/Furnace blower not activated when VEB120S is running

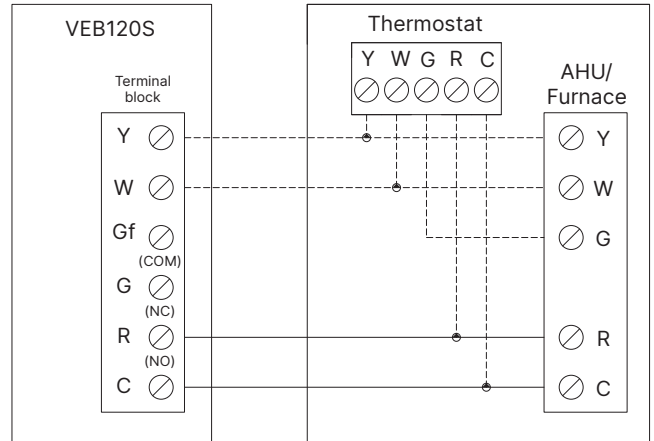
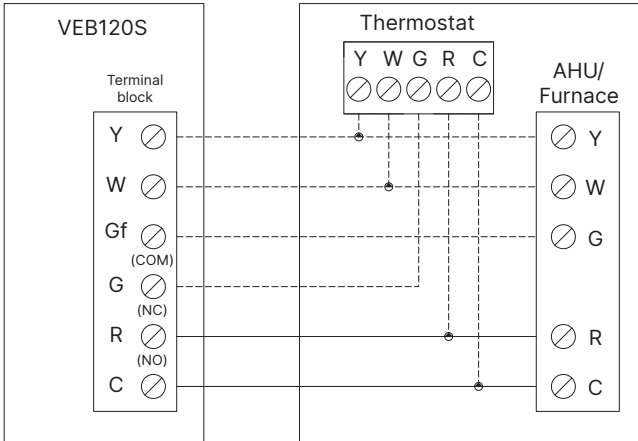

Wall switch

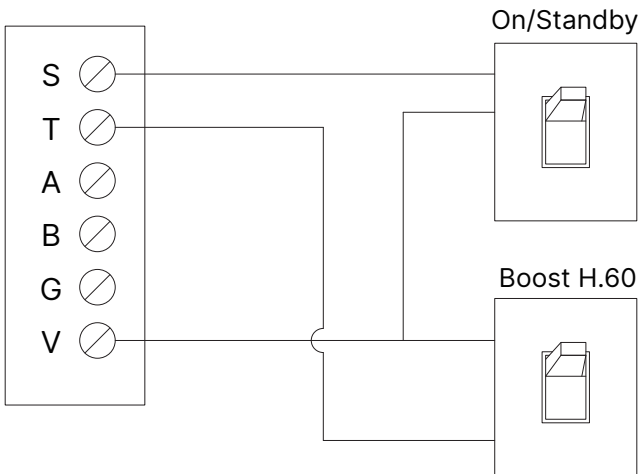

————— Mandatory Installation Wiring
 - - - - - Optional Installation Wiring

OPERATION

Follow the below step to operate the product.

1. Connect the control panel by wire, refer to INSTALLATION (CONTROL PANEL) section.
2. Connect the wire of HVAC/ AHU signal connector and RS485 connector.
NOTE: No need to connect if you don't need those function.
3. Plug in the power cord (120V / 60HZ)
Caution: Please ensure the maintenance door is closed before starting the product.
4. Turn on the main switch.

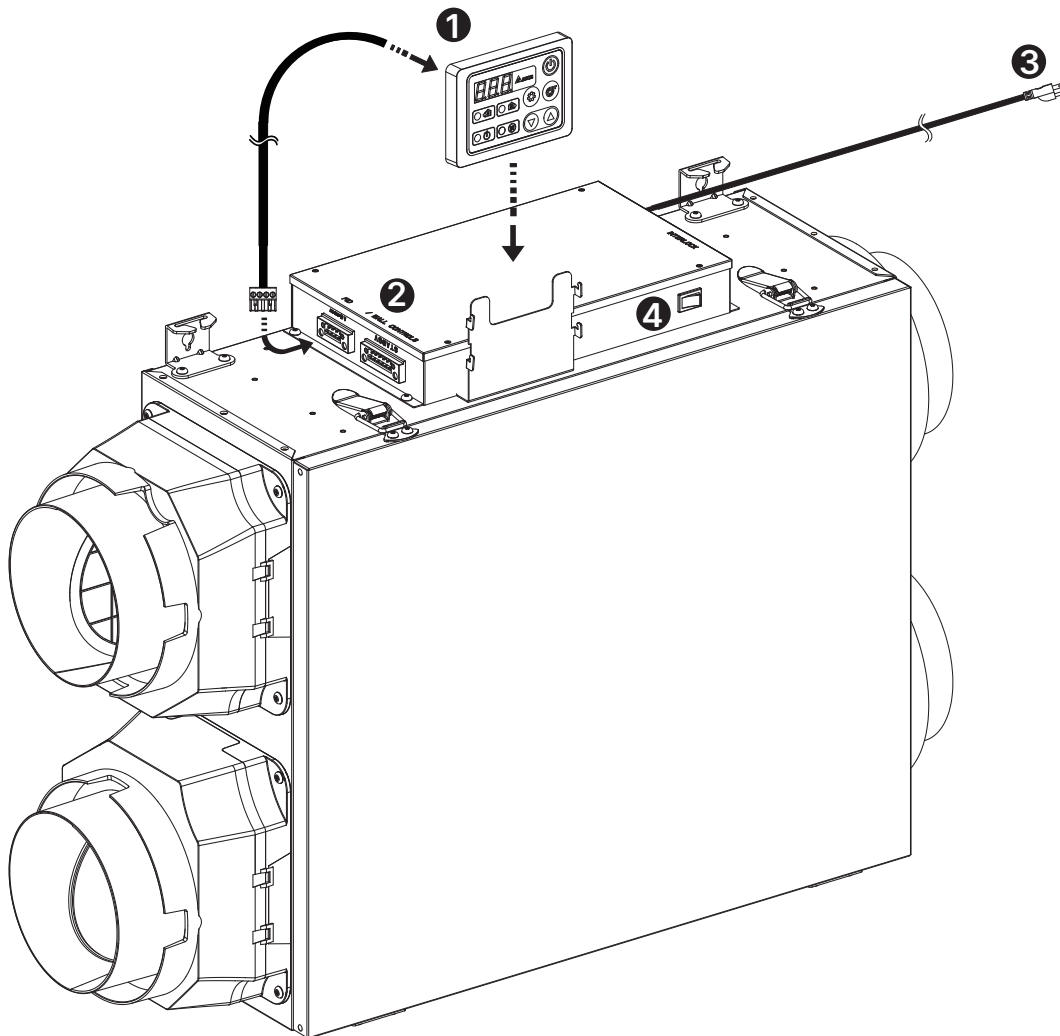

INSTALLATION (CONTROL PANEL)

Follow the below step to operate the product.

1. Use 2 pcs screws to secure the panel bracket.
2. Control panel inserts into bracket groove.

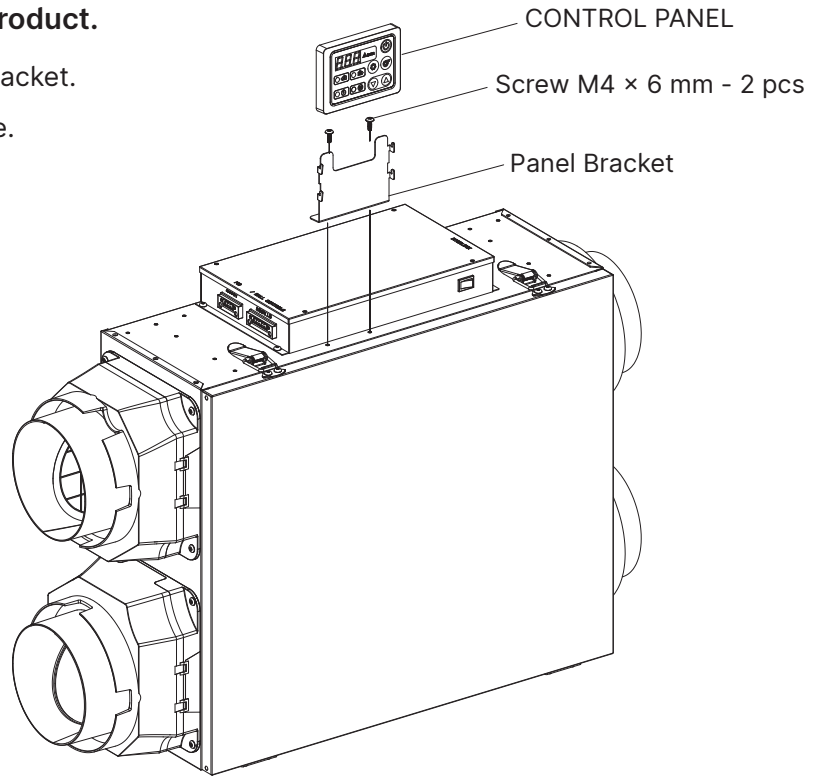

WIRING PREPARATION



Recommended to use the cable (AWG #14~#26), 2 ft (0.6 m) for connecting product and control panel, and the length should not be longer than 100 ft (30 m).

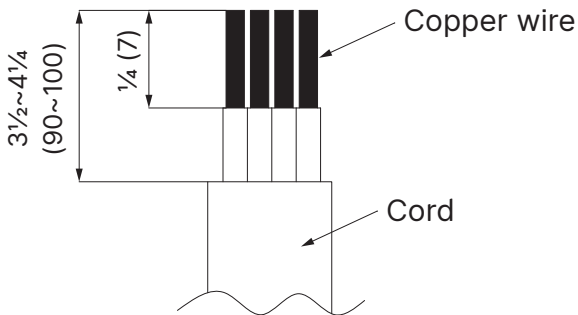

Note: Strip the insulation off each wire.
Unit: inches (mm)

WIRING DIAGRAM

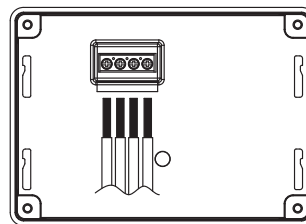

Don't press the screen, it may cause V distortion or break altogether.

Make sure cables are not caught by V circuit-board or resin clip. Otherwise, it may cause electrical leakage.







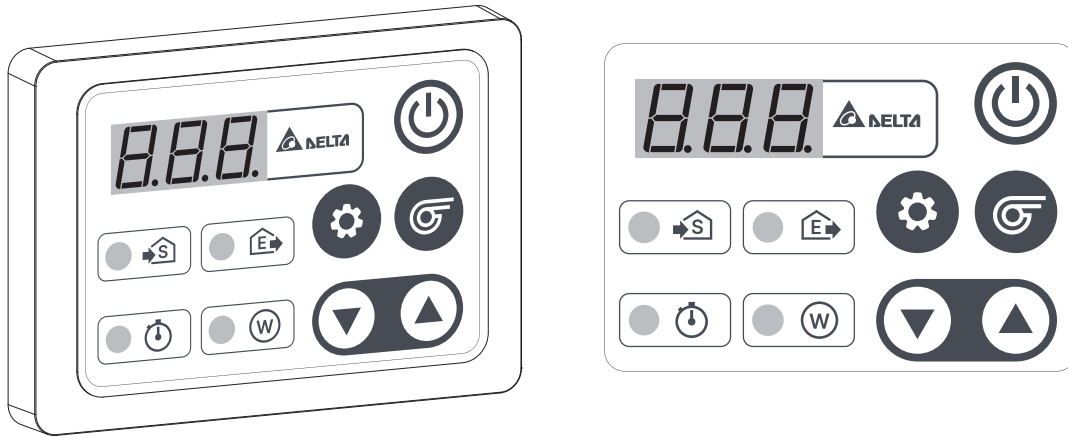

Need to be tightened and not loosened.

CONTROL PANEL

Note: All Delta ERV can be controlled by control panel.

The control offers the most advanced features to control your home's ventilation with complying with California Title 24, Part 6 Sections 150.1(c)7A and 150.2(b)1E.



ICON	FUNCTION	DESCRIPTION
	Power on/off	Unit is enable/disable when press the button.
	Boost mode	The airflow can be changed to maximum with 20/40/60 minutes one time.
	Select and set	Select display function/Set airflow and run-time value.
	Adjust settings	Adjust the airflow and run-time value.
	Supply air indicator	If the indicator is illuminated, monitoring the supply airflow. If the indicator is flashing, supply airflow can be changed by button.
	Exhaust air indicator	If the indicator is illuminated, monitoring the exhaust airflow. If the indicator is flashing, exhaust airflow can be changed by button.
	Run-time indicator	If the indicator is illuminated, monitoring the run-time. If the indicator is flashing, run-time can be changed by up/down button to 5~60 minutes per hour. The timer satisfy ASHRAE standard to adjust indoor airflow exchange per hour.
	Power consumption indicator	Monitoring the power consumption when the indicator is illuminated.
	7-Segment display	It can show setting value or monitoring value

CONTROL PANEL - Continues

Tips for Settings



Power on/off

Press the button to turn on/off the unit.

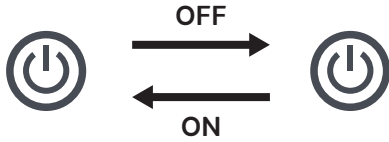

Boost on/off

Press button one time to increase 20 min, the cycle is 20 min → 40 min → 60 min → cancel boost mode. If forcing stop it, pressing the boost button over 3 seconds.

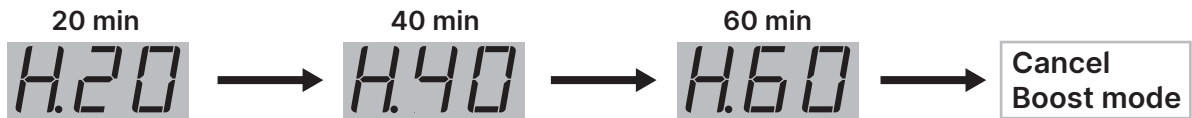

*Boost mode operation examples

After running 40 minutes, unit will get be original status. Auto counting from 40, 39, 38...3, 2, 1min to stop boost mode.

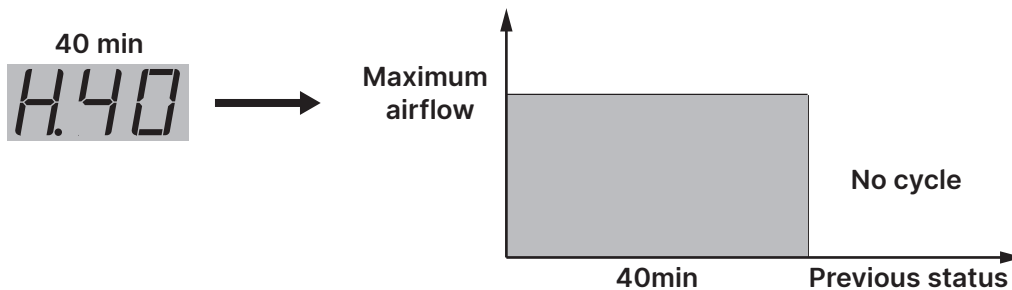

Select (cycling display)

Press button one time to select function as follows.

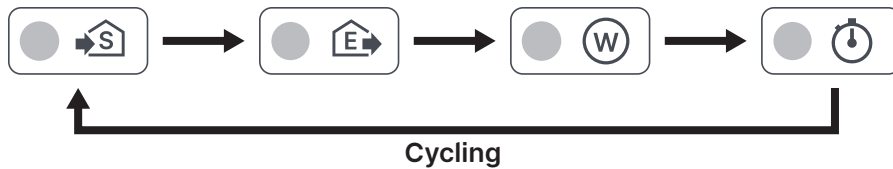

CONTROL PANEL - Continues



Airflow

Press button to select airflow as follows.

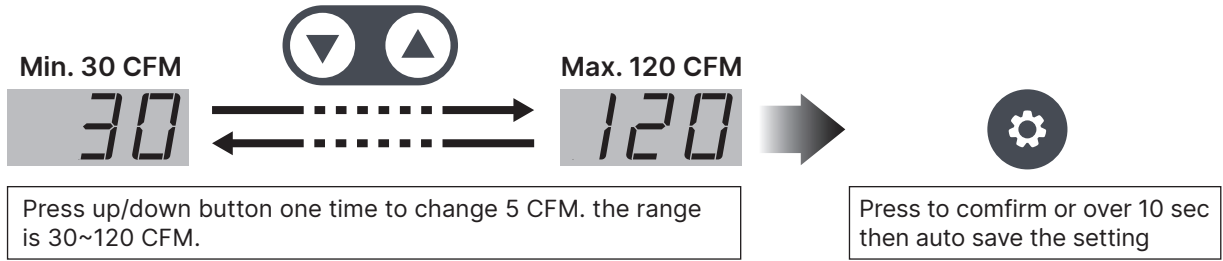

*Operation examples

1. Monitoring airflow



2. Setting airflow



Run-time

Press button to select run-time as follows.



*Display Hints

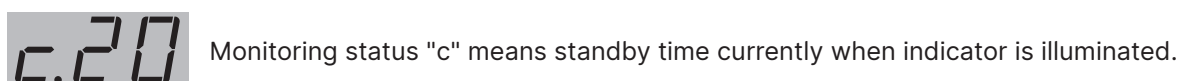
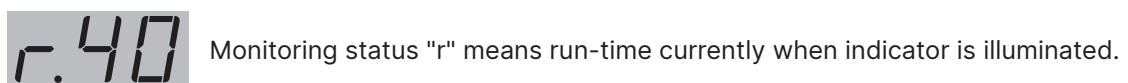
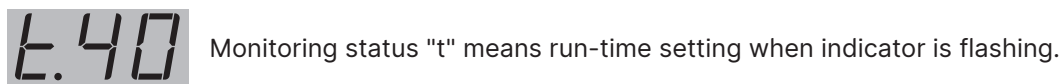

CONTROL PANEL - Continues

*Run-time operation examples

1. Run 40 minutes and standby 20 minutes setting

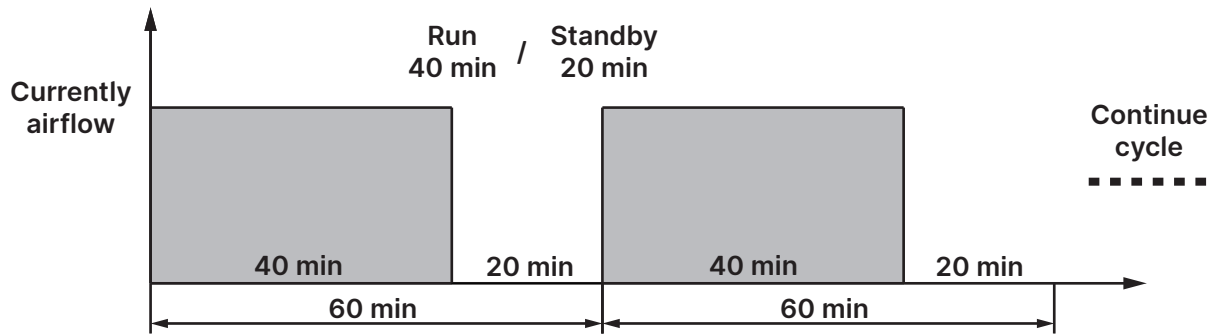
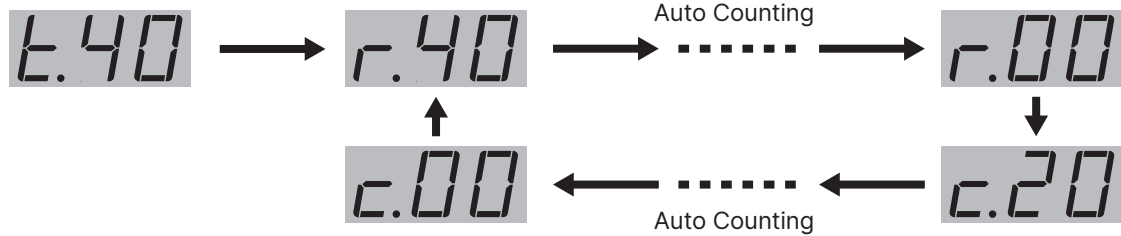

2. Run 60 minutes and standby 0 minutes setting (Continue operating setting)

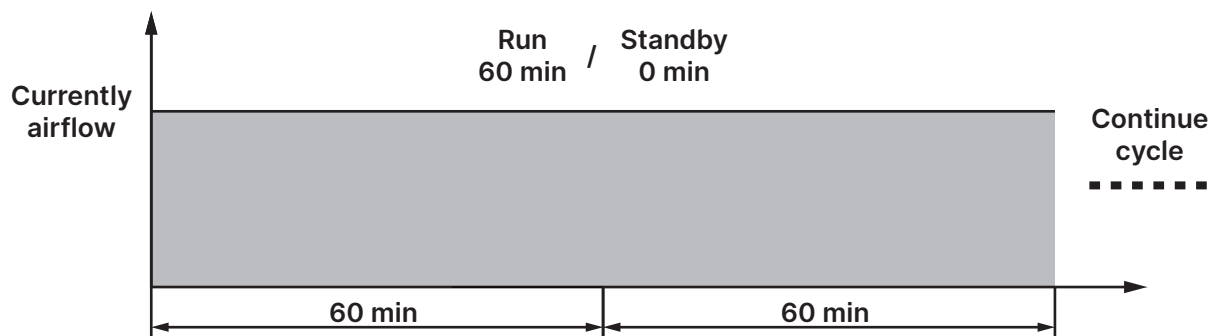

Defrost mode

Monitoring status "dEF" means defrost mode when temperature drop below -10C.



MAINTENANCE

 WARNING	<p>To prevent the electrical shock may result, please stop the unit and unplug it. Always wearing the gloves and glasses is recommended during the maintenance and repairs.</p>
CAUTION	<ol style="list-style-type: none"> 1. For long-term and safe use of the product, routine maintenance must be done by authorized person(s) at least every 6~ 12 months. 2. Pay attention to dust, condensation water or parts which may drop down when the door is opened. 3. Do not allow water to enter the product. 4. Never use the petrol, benzene, thinner or any other such chemicals for cleaning the product.

Filter cleaning and replacing

1. Open the Maintenance Door.
2. Remove the OA Pre-filter , MERV 13 filter and RA Pre-filter.
3. Clean the filter by vacuum cleaner.
4. Close the Maintenance Door.

<p>(1) Open the Maintenance Door</p>	<p>(2) Remove the ERV core and filter.</p>
<p>(3) Clean the ERV core and filter by vacuum cleaner.</p>	<p>(4) Close the Maintenance Door.</p>

MAINTENANCE - Continues

Filter maintenance reminder

The display will be show "F01" when the product accumulated running time reaches to 3 months and show "F02" when the product accumulated running time reaches to 6 months. Press "up and down" button simultaneously for 2 seconds to erase the error code. If running time reaches 6 months, reset the timer.

If wanting to reset the timer forcedly, press "up and down" button simultaneously for 5 seconds to reset the timer, display shows "F00".

Operating as below:

- **Erase the 3 months reminder**

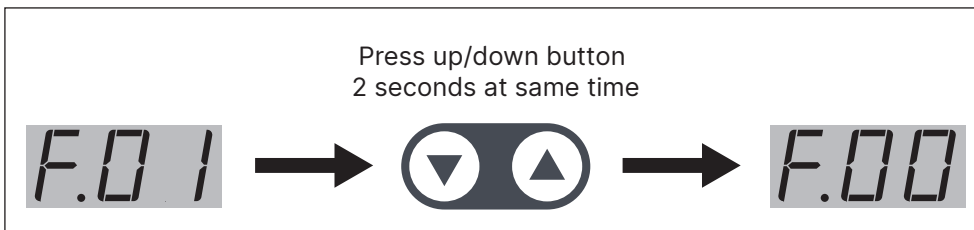

- **Reset the 6 months reminder**



- **Forced to zero the time reminder**

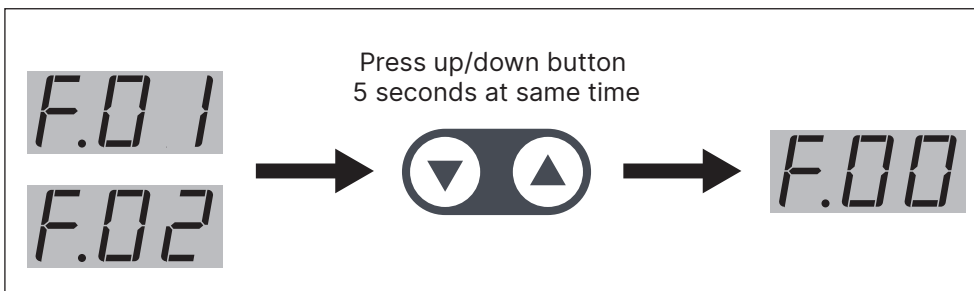

Note: The Unit can still be operated when reminder is displayed, but it is recommended to replace filter as soon as possible.

TROUBLE SHOOTING

Problem	Possible reason	Action
The ERV doesn't work	<ul style="list-style-type: none"> • Is the power cord connected to the host? • Is the power cord connected to circuit breaker of electric panel? • Is the host connected to the main switch? 	<ul style="list-style-type: none"> • Check the power cord is connected. • Please check that the circuit breaker is used alone and must have a capacity of 10A or more. • If power went off, please restart the power.
Abnormal sound or vibration	<ul style="list-style-type: none"> • Is host machine installed correctly? • Is duct installed properly? • Is there any air leakage? 	<ul style="list-style-type: none"> • Make sure ERV is horizontal and fixed. • Follow the installation(ductwork) section. • Do not over-bend air duct and make it smooth. • Check all the joints and pipes being sealed up and taped
Air flow become smaller	<ul style="list-style-type: none"> • Filter blockage 	<ul style="list-style-type: none"> • Clean the filter. (Do not wash by water) • Replace the filter.

FAULT INDICATOR DISPLAY(FID)

Code #	Descriptions
F00	Reset timer of filter maintenance
F01	Clean two primary filters and replace MERV 13 filter via operating days
F02	Replace two primary filters and MERV 13 Filter via operating days
E01	Supply airflow abnormal
E02	Exhaust airflow abnormal
E03	Temperature sensor failure
E04	Temperature too high / Low
E05	Communication error

WARRANTY

DELTA ELECTRONICS FIVE YEAR LIMITED WARRANTY

Delta Electronics Inc. ("Delta Electronics") warrants to the original consumer purchaser in the USA that the Breez ventilation fan products will be free from defects in material or workmanship. This warranty is limited to FIVE (5) years from the original date of purchase.

Limitations and Exclusions

1. During the warranty period, a replacement for any defective product will be supplied free of charge for installation by the consumer. The warranty provided herein does not cover charges for labor or other costs incurred in the troubleshooting, repair, removal, and installation service.
2. All returns of defective parts or products must include the product model number, and must be made through an authorized Delta Electronics distributor. Authorized returns must be shipped prepaid. Repaired or replacement products will be shipped by Delta Electronics F.O.B. shipping point.
3. Delta Electronics shall not be liable for any indirect, incidental, consequential, punitive, or special damages.
4. Arising out of or in connection with products use or performance, regardless of the form of action whether in contract, tort (including negligence), strict product liability or otherwise.
5. The warranty does not cover if user does not comply with manufacturer's installation manual.
6. To qualify for warranty service, you must notify Delta Electronics at the address or telephone number below.
7. Delta Electronics shall have no liability to the original owner-user with respect to any defect caused by abuse, misuse, neglect, improper transportation or storage, improper testing, improper installation, improper operation, improper use, improper maintenance, improper repair, improper alteration, improper modification, tampering or accident of products or parts thereof, or unusual deterioration or degradation of products or parts thereof due to a physical environment beyond the requirements of products' specifications.

Address: 46101 Fremont Boulevard, Fremont, CA 94538

US Toll Free Number:

1-888-979-9889 – Technical Support

1-877-685-4384 – Customer Sales Support

www.deltabreez.com